

# WALL MOUNT SINGLE SECTION ENCLOSURES



## DESCRIPTION

Datacom single-section wall mount cabinet is suitable for applications where security and accessibility are required and floor space is at a premium. The cabinets are designed to hold multiple pieces of voice/data equipment comfortably. Datacom wall mount cabinets are constructed with rigid frames that can be fitted on a wall, ventilation is provided to allow active equipment to be installed, making it an ideal solution for small LANs, retail units, and remote sites. Datacom single-section wall-mounted enclosures are designed to hold standard 19" rack-mount equipment and patch panels. The cabinet features a lockable glass door, adjustable front profiles, and removable entry plates at the top and bottom.

## APPLICATION

- LAN & WAN networking
- Telecommunications
- Network wiring closets
- Audio / Video System
- Security System

## STANDARDS COMPLIANCE

- ANS/EIA RS-310-D
- IEC297-2
- DIN41491
- ETSI Standard

## FEATURES

- Welded frame, single section, compatible with 19" standard equipment.
- Tempered glass front door with over 180 turning degrees.
- Removable side panel, easy to install and lock optional.
- Cable entry on the top and bottom
- Fan cutout on the top, easy to install the fan.
- Installing back panel, easy to fix on the wall.
- Various accessories for option
- Optimizes airflow for improved heat dissipation from various switches and power supplies.
- Allows cabinet to swing freely for easy operation even under maximum load capacity

## STANDARD PACKAGING

- Assembled Cabinet and keys, locks, two adjustable ANS/EIA RS-310-D complied cage nut rails, removable cover panel for vent on top of cabinet, assembly hardware and rear cable routing accessory kit.

# WALL MOUNT SINGLE SECTION ENCLOSURES

## CONSTRUCTION

Material	SPCC quality cold rolled steel Thickness: 1.2mm Tempered glass Thickness:5mm
Loading Capacity	Static loading: 80kg
Degree of protection	IP20
Surface Finish	Painted with high-quality polyester baked oven-dried protective paint.
Front panels	3mm tempered glass fitted with end metal panels. Left and right side hinge options supplied with cylinder lock and keys.
Side panels	Quick-release lockable and removable side panels.
Rear Plate	Removable rear plate.
Color	RAL 7035 / RAL 9005.
Ventilation	Two grill cutouts are provided on the top Panel to accommodate 120X120mm fans. Ventilation slots on the top, bottom, and sides of the cabinet..

## TECHNICAL DRAWINGS

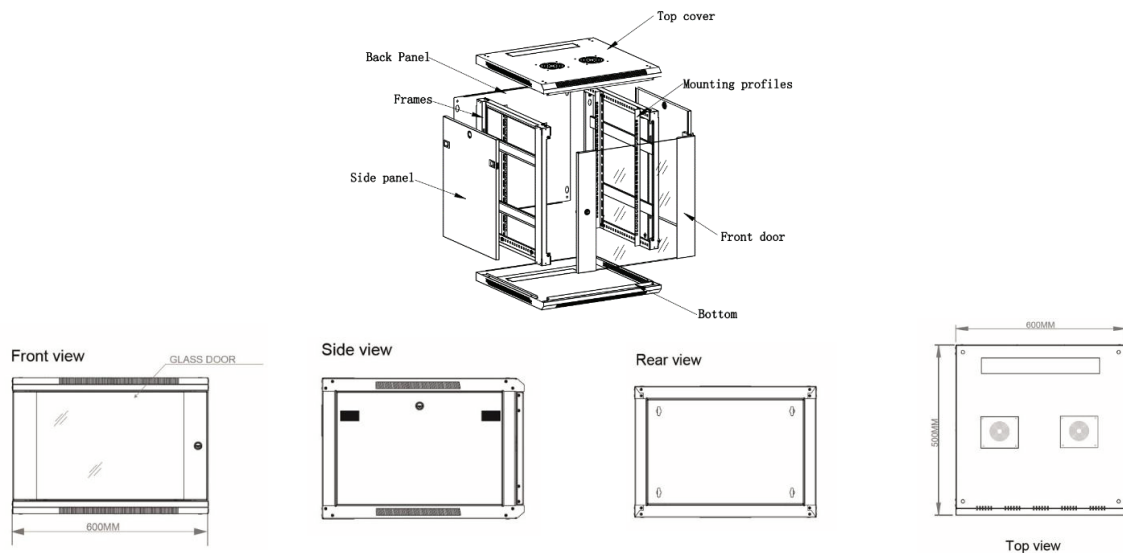

## ORDERING INFORMATION

### Description

**Datacom Single Section Wall Mount Cabinet Removable Side Panel With 19"Equipment Rack**

### Part No.

**DC-RK-xx-WS-y\*\***

Where "DC" is constant denotes Datacom,  
 RK= Rack, "xx" for Cabinet height range varies from 06 to 21  
 WS stands for 'Wall mount Single Section  
 Variable 'y' stands for the cabinet depth – value is 1 & 4. 1=500mm, 4=600mm  
 \*\* indicates color. If no value by default cabinet color is White gray RAL 7035  
 \*\* B – denotes the black color